



OBSERVATOR

instruments



OMC-140 Multifunctional NMEA display

Operators' Manual

Version 1.04 - 2015

Author: Observer Instruments

Revisions:

1.01	July 2014	First issue
1.02	Oct 2014	Preliminary edition
1.03	April 2015	Test Manual
1.04	Dec 2015	First Release

Index

1	Introduction	5
2	Safety	6
3	Display functions	7
3.1	Home screen Wind	7
3.2	Home screen GPS	10
3.2.1	Default Home screen functions:	10
3.2.2	Touch Buttons:	11
3.2.3	Default Indicators:	12
3.3	Home Screen Heading	13
3.3.1	Default Home screen functions:	13
3.3.2	Touch Buttons:	14
3.3.3	Default Indicators:	15
3.4	Available indicators:	16
3.5	General Settings Screen	19
3.5.1	Average (wind only)	20
3.5.2	Wind Speed (<i>wind only</i>)	20
3.5.3	Dimming control	20
3.5.4	Sensor Selection	20
3.5.5	Speed reference (<i>wind only</i>)	20
3.5.6	User Avg.(Average) Interval (<i>wind only</i>)	20
4	Advanced functions	22
5	Wind Display Orientation: Relative vs Theoretical vs True	22
5.1	Wind display orientation	22
5.2	Drift	22
5.2.1	Heading vs Course	22
5.2.2	Speed through water (VHW from speed log) vs Speed over ground (gps)	22
6	Wind Orientation Reference Requirements	23
7	Terms, Abbreviations & Symbols list	23
7.1	Terms & Abbreviations used in this manual	23
7.2	Symbols	24
8	Digital interface	25
8.1	NMEA software	25
8.1.1	Inputs:	25
8.1.2	Outputs:	25
8.2	NMEA Message description	26
9	Connections	30
9.1	Main connections	30
9.2	DC power module connections	31
9.3	Remote keypad and relay module	31
10	Options	32
10.1	Remote control unit	32
11	Specifications	33
11.1	Inputs/Outputs	33
11.2	TFT touch screen	33
11.3	Electrical	33
11.4	Environmental specifications	33
11.5	Dimming possibilities	33
11.6	Dimensions (see drawings on following page)	33
11.7	Alarms	34
11.8	In accordance with	34
12	Dimensional drawings	35
13	Menu structure Touch screen	36
14	Appendix: Declaration of Conformity	39

Page intentionally left blank

1 Introduction

The OMC- 140 is a multi functional NMEA display primarily designed for wind information. It is capable of calculation Theoretical and True wind if required data is available.

This manual is intended for the Operator of the display.

An Operators Guide with the basic essential information is also available.

For installation instructions we kindly refer to the Installation manual.

The Installation manual also contains information for the system administrator.

2 Safety



**Do not open display.
Potential lethal voltages inside.
No user exchangeable parts inside.**



**Only use indoors.
For outdoor use an IP66 or better housing is required.**



For correct functioning of this display the display and connected sensors must be installed according installation instructions as described in the OMC-140 Installation manual.



**Remember: instruments are tools.
They do NOT replace your own observations!**



After end of life dispose this product according local regulations or return to manufacturer.

3 Display functions

The examples used in this chapter display the default layout. It is possible to customize the layout by adding, removing parameters or change their position.

3.1 Home screen Wind



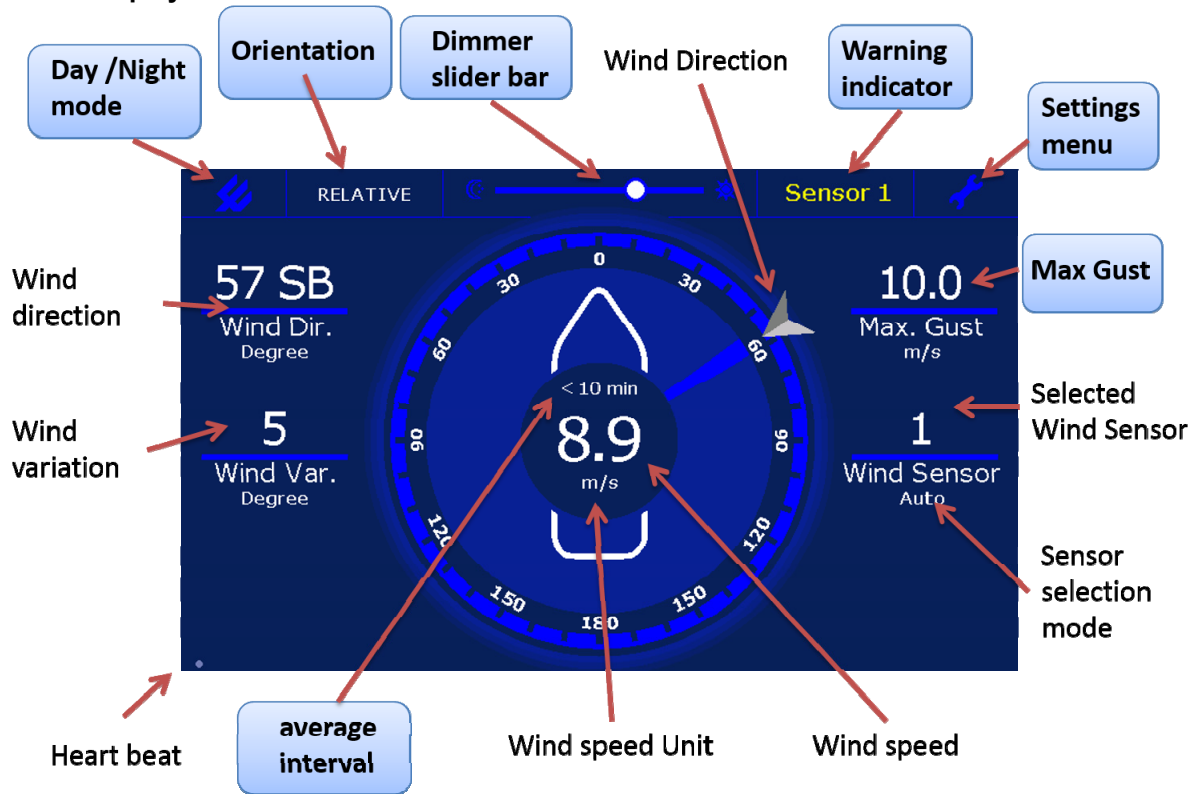

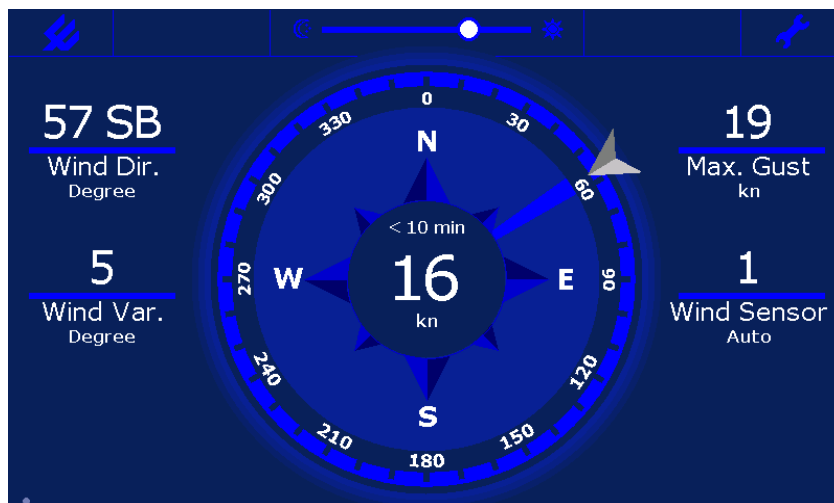

Marine Display:









Land Display:





Home screen 'buttons':

	Select between Day or Night mode. In Night mode a darker color palette reduces the emitted light intensity.
	Brightness slider bar. In Automatic or NMEA control mode use this to set an offset.
	Opens the settings menu
	Only visible when an alert is active. Touch this button to acknowledge the alarm.
	Changes orientation of the display: Relative, Theoretical or True Availability of the orientations depends on received data. (Marine display only).
	Changes average interval: 10 min, 2 min, Instant or User*. '<' indicates the selected interval has not yet been met. <i>*User is a custom selectable interval which can be set via the settings menu.</i>
	Resets the maximum Gust when the averaging is set to Instant.

3.1.1 Home screen indicators:

	Selected Orientation. Relative, Theoretical or True (Marine display only)
	Wind Direction indicator. Shows the average wind direction over the selected interval time.
	Wind direction variation over the selected average interval time. Also in the wind circle visualized in light blue: 
	Shows max Gust over the selected interval time. If 'Instant' is selected it shows the Max Gust since last reset. Touch to reset
	Selected wind sensor and selection mode.

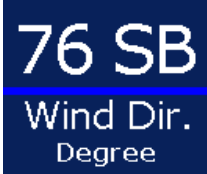
	<p>Average interval time. 10 min, 2 min, Instant or User</p> <p>Wind speed average over the selected interval time.</p> <p>Wind speed Unit. Bft, Mph, m/s, Kts or km/h</p>
	<p>Heart beat. The dot should be running from left to right to indicate the display is working and not frozen.</p>
	<p>Wind direction variation over the selected average interval time.</p>
	<p>Average wind direction over the selected average interval.</p>



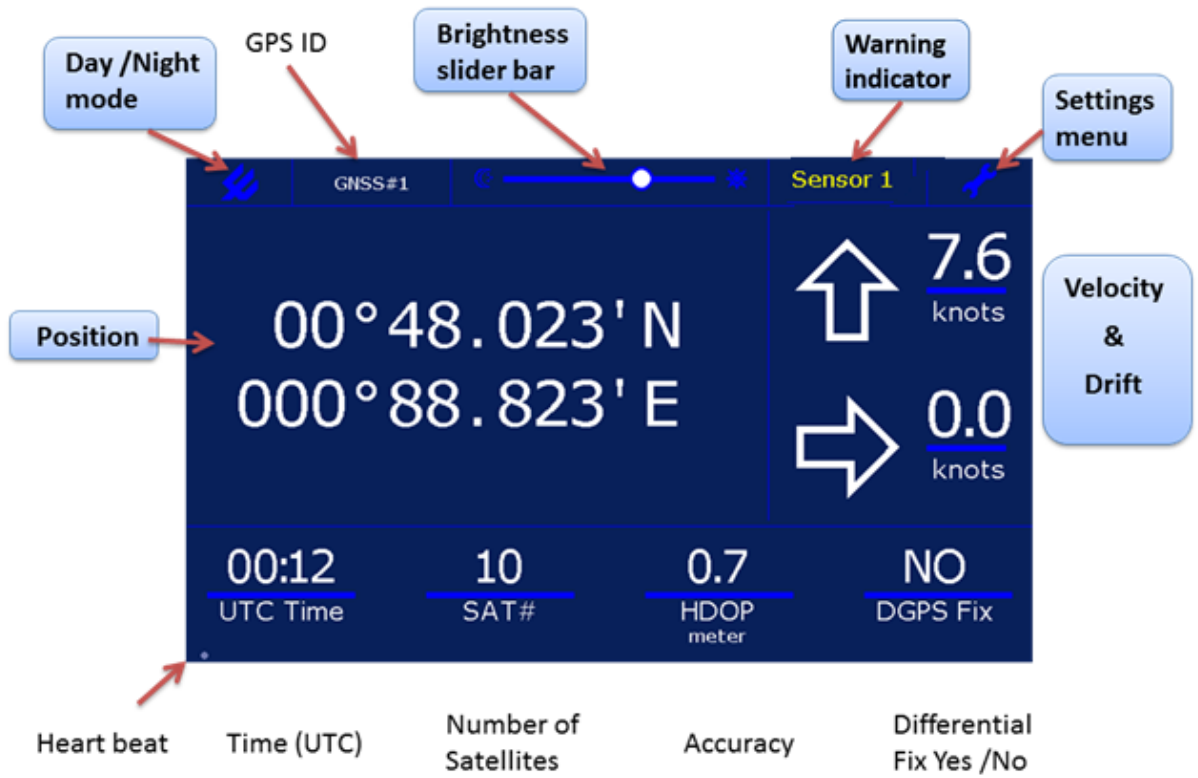

3.2 Home screen GPS

3.2.1 Default Home screen functions:



3.2.2 Touch Buttons:



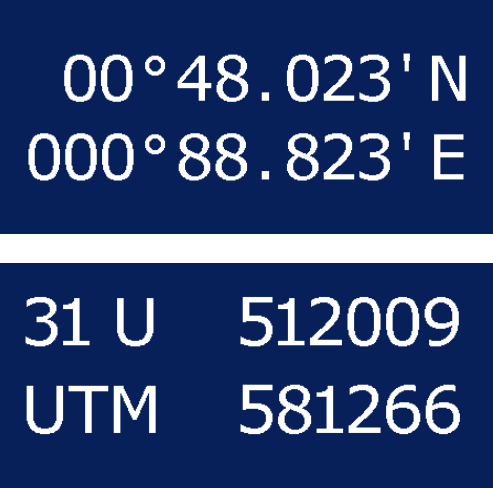
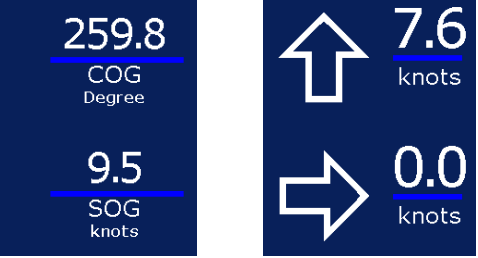



Note: The display is single touch, the display will not respond if multiple touch is detected. Don't place your hand on the edge while trying to touch a button, this could be detected as a touch.

	<p>Select between Day or Night mode. In Night mode a darker color palette reduces the emitted light intensity.</p>
	<p>Brightness slider bar. In Automatic or NMEA control mode use this to set an offset.</p>
	<p>Opens the settings menu</p>
	<p>Only visible when an alarm is active. Touch this button to acknowledge the alarm.</p>
	<p>Geographical Position (GGA)*</p> <p>Touching will toggle between UTM data** if available and the Geographical data</p> <p>**Requires UTM data input (GMP)*.</p>
	<p>Speed and Course over ground (VTG)*</p> <p>Touching will switch to Arrow Speed display (Velocity & Drift) if available***.</p> <p>***Requires Heading data input (HDT or THS)*.</p>

* Reference to the required NMEA input message

3.2.3 Default Indicators:

These are the factory default .

	GPS Identifier. Can be set in the Settings menu
	Heart beat. The dot should be running from left to right to indicate the display is working and not frozen.
	UTC time (GGA)*
	Number of Satellites (GGA)*
	Accuracy HDOP (GGA)*
	Differential Signal received YES / NO (GGA)*

* Reference to the required NMEA input message



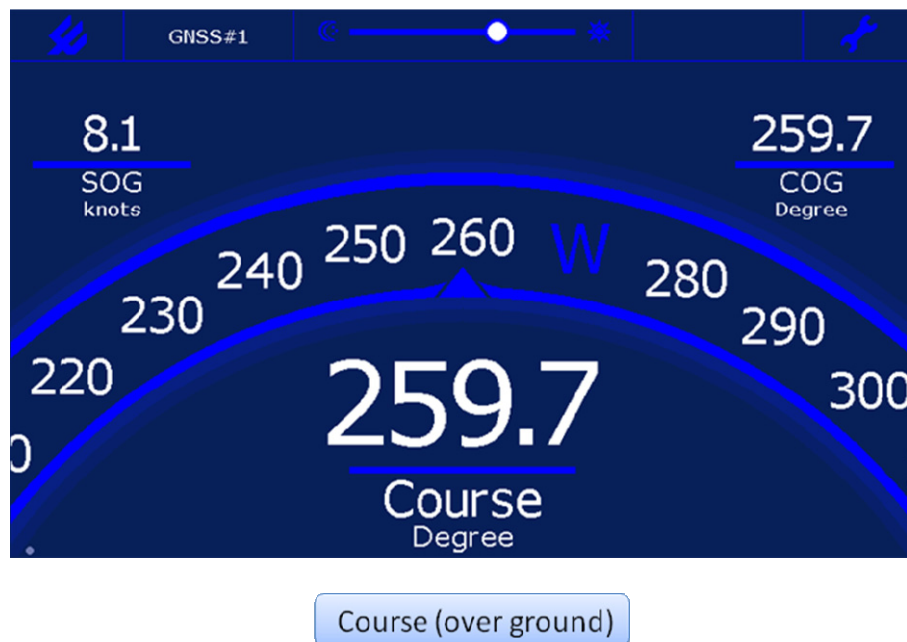
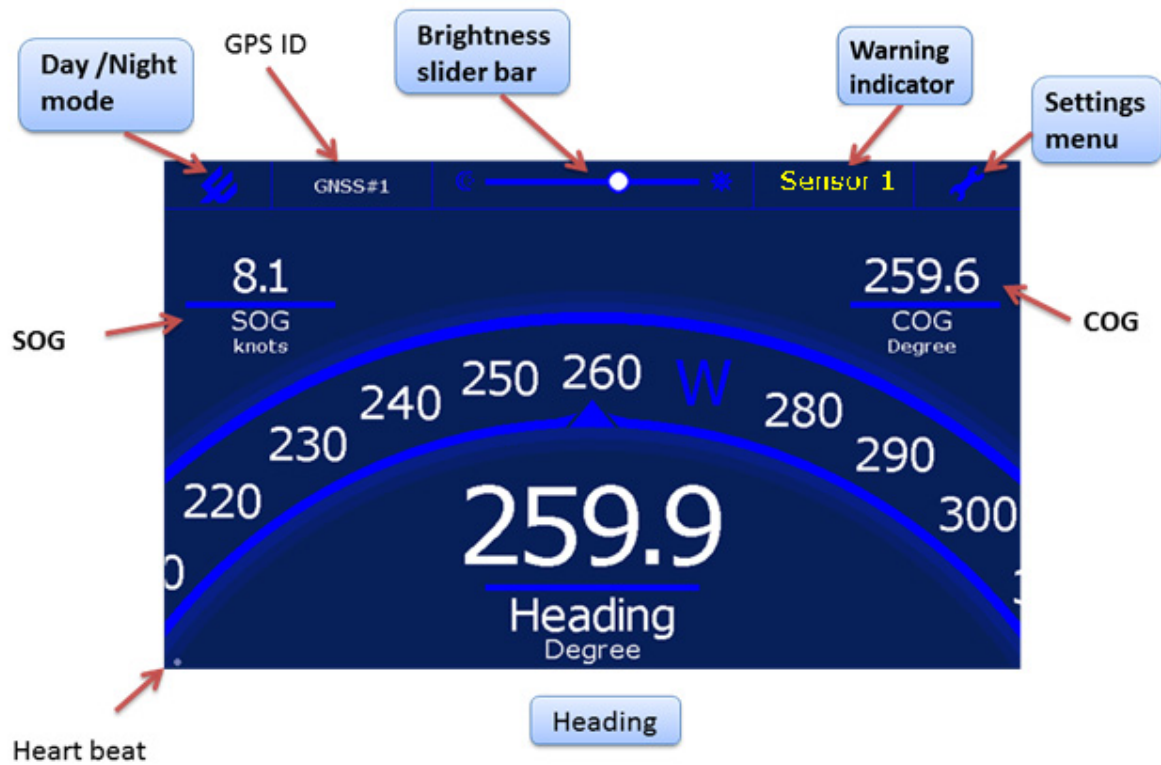

3.3 Home Screen Heading

3.3.1 Default Home screen functions:



3.3.2 Touch Buttons:





Note: The display is single touch, the display will not respond if multiple touch is detected. Don't place your hand on the edge while trying to touch a button, since this could be detected as a touch.

	Select between Day or Night mode. In Night mode a darker color palette reduces the emitted light intensity.
	Brightness slider bar. In Automatic or NMEA control mode use this to set an offset.
	Opens the settings menu
	Only visible when an alarm is active. Touch this button to acknowledge the alarm.
<div data-bbox="193 880 700 1155" style="background-color: #002060; color: white; padding: 10px; text-align: center;"> <h1 style="margin: 0;">5.0</h1> <hr style="border: 1px solid white; margin: 5px 0;"/> <p style="margin: 0;">Heading Degree</p> </div> <div data-bbox="193 1182 700 1458" style="background-color: #002060; color: white; padding: 10px; text-align: center;"> <h1 style="margin: 0;">259.7</h1> <hr style="border: 1px solid white; margin: 5px 0;"/> <p style="margin: 0;">Course Degree</p> </div>	<p>Heading from Gyro (THS or HDT)*</p> <p>Touch will toggle between Heading and Course</p> <p>Course Over Ground (VTG)*</p>

* Reference to the required NMEA input message

3.3.3 Default Indicators:

These are the factory default indicators:

	GPS Identifier. Can be set in the Settings menu
	Heart beat. The dot should be running from left to right to indicate the display is working and not frozen.
	Speed Over Ground (VTG)*
	Course Over Ground (COG)*

** Reference to the required NMEA input message*

3.4 Available indicators:

These can be configured for all display types in the Advanced menu.

Please Note: **The corresponding NMEA message must have been received by the display at least once before an indicator can be selected!**

<p>6.0 Max. Gust m/s</p>	<p>Maximum Gust over the selected interval time. If 'Instant' is selected it shows the Maximum Gust since last reset. (MWV or MWD)*</p> <p>Touch to reset</p>
<p>76 SB Wind Dir. Degree</p>	<p>Wind Direction (MWV or MWD)*</p>
<p>16 Wind Speed kn</p>	<p>Wind Speed (MWV or MWD)*</p>
<p>1 Wind Sensor Auto</p>	<p>Selected Wind Sensor indicator (MWV or MWD)*</p>
<p>33 Wind Var. Degree</p>	<p>Wind variation (MWV or MWD)*</p>
<p>972.0 Baro. QFE hPa</p>	<p>Barometric Pressure QFE (at Runway / Helideck Level).(XDR)*</p>
<p>961.0 Baro. QNH hPa</p>	<p>Barometric Pressure QNH (at Sea Level) (XDR)*</p>
<p>19.7 Temperature °C</p>	<p>Air Temperature (XDR)*</p>

3.1 <hr/> Dew Point °C	Dew Point (XDR)*
8.1 <hr/> SOG knots	Speed Over Ground (VTG)*
259.7 <hr/> COG Degree	Course Over Ground (VTG)*
259.9 <hr/> Heading Degree	Heading from Gyro (HDT or THS)*
00:12 <hr/> UTC Time	UTC time (GGA)*
NO <hr/> DGPS Fix	Differential Signal received YES / NO (GGA)*
10 <hr/> SAT#	Number of Satellites (GGA)*
0.7 <hr/> HDOP meter	Accuracy HDOP (GGA)*
1.0 <hr/> Diff Age seconds	Age of last received Differential signal (GGA)*
1618 <hr/> Visibility meter	Visibility (Dedicated message non NMEA)

<p>DZ Pres. Weather</p>	<p>Present Weather (Dedicated message non NMEA)</p>
<p>0.082 Deviation Lat. meter</p>	<p>Deviation of the Latitude (GST)*</p>
<p>0.153 Deviation Lon. meter</p>	<p>Deviation of the Longitude (GST)*</p>

** Reference to the required NMEA input message*

3.5 General Settings Screen

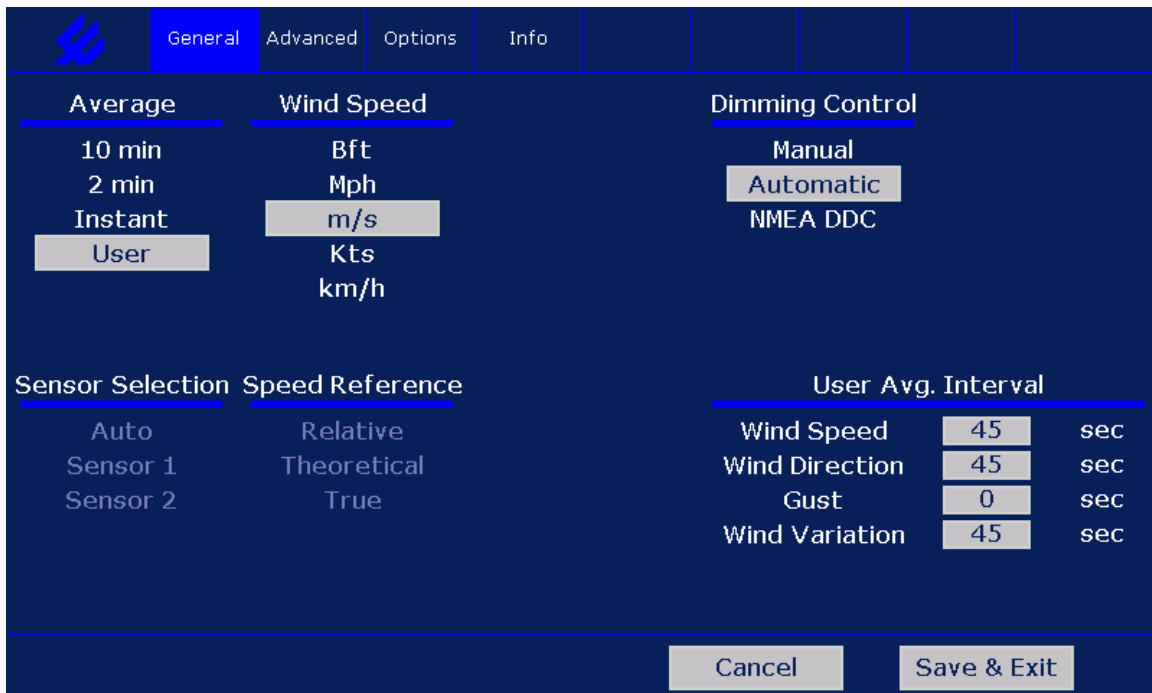

The General Settings Screen is accessible for all users, but some functions can be locked by the administrator, while others might not be available for other reasons.

NOTE: General settings display the stored DEFAULT settings, which will be used whenever the display is started. Settings done via the Home screen are considered temporarily changes and not automatically stored in the default settings.

Grayed out blocks are not accessible. For example: the 'User Average Period' is only accessible when 'User' is selected at 'Average Period'.

The screen is divided in blocks. Touching it will zoom in and allow you to make changes.

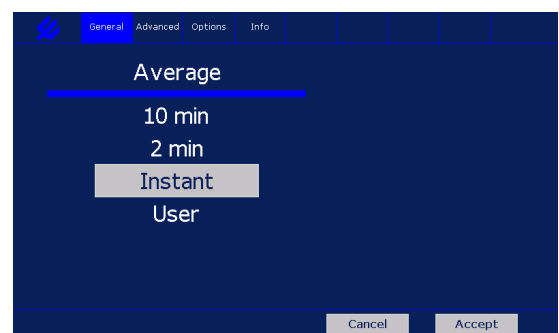

Use 'Save & Exit' to store your changes and return to the Main screen. Otherwise use 'Cancel' to discard all changes and return to the Main screen. Display will also return to normal operation if no touch is detected for 1 minute.

3.5.1 Average (wind only)

Set the interval over which all data (except Gust) will be averaged.

Gust will be given over the selected interval (2 & 10 minutes), since last reset (Instant) or at User setting (User).

Normally wind information is reported in 10 minute average data. During specific changing conditions you will need to change to 2 minutes average. The OMC-140 can detect those conditions and change automatic between 10 & 2 minute average if 'Marked Discontinuity' is set in 'Advanced Settings (default is off).

3.5.2 Wind Speed (*wind only*)

Selection of wind speed unit.

3.5.3 Dimming control

Select how you would like to control the brightness of the screen.

Manual: Brightness is set by the slider bar only

Automatic: Brightness is controlled by the built in light sensor. The slider bar can be used to set an offset.

NMEA DDC: Brightness is controlled by the NMEA DDC protocol. This can be another display or any other device using the NMEA DDC protocol. The slider bar can be used to set an offset.

3.5.4 Sensor Selection

Only selectable when 2 sensors are connected, otherwise it will be grayed out.

Auto: Sensor with highest wind speed will be selected

Sensor 1: Data of sensor on port 1 will be displayed

Sensor 2: Data of sensor on port 2 will be displayed

3.5.5 Speed reference (*wind only*)

Options are only selectable if the required data is available (see chapter 6)

Relative: Wind direction & speed data related to the bow of the vessel

Theoretical: Wind direction & speed data related to the bow of the vessel as if the vessel would have no speed (True wind related to the bow).

True: Wind direction & speed data related to true North

3.5.6 User Avg.(Average) Interval (*wind only*)

Set the values for the 'User' settings at 'Average'.

- For Wind Speed, Direction & Variation this is the Average interval in seconds.
- For Gust this is the reset time (Gust is always a 3s average).
- Valid values are 0 – 600 (seconds).



User Avg. Interval	
Wind Speed	45 sec
Wind Direction	45 sec
Gust	0 sec
Wind Variation	45 sec

45

7 8 9 .

4 5 6 CLR

1 2 3 DEL

0 ENTER

Cancel Accept

4 Advanced functions

This menu is meant for the system administrator and therefore password protected. Besides installation parameters it allows to lock and unlock settings in the General menu, which can be accessed by the Operator.

5 Wind Display Orientation: Relative vs Theoretical vs True

5.1 Wind display orientation

Depending on available data the OMC-140 display is able to display the wind data up to 3 orientations in the marine mode. This mode is fixed during installation, in land mode only the True to North mode is available: a wind rose is displayed and the area between the logo and dim control bar will be empty.

Relative orientation:

- vessel symbol is displayed
- Wind is displayed as measured on board,
Wind is displayed relative to the bow off the vessel.

True orientation:

- Wind Rose is displayed
- Wind is displayed as if the vessel would not move heading North.
Wind is displayed True to North.

Theoretical orientation:

- Vessel symbol is displayed
- Wind is displayed as if the vessel would not move
The wind is displayed True to the bow of the vessel.

True and Theoretical wind speed will always be identical, direction difference will be the heading of the vessel (or course if no heading data is available).

When the vessel is heading North, Theoretical & True values will be identical.

5.2 Drift

5.2.1 Heading vs Course

To compensate for drift the display requires heading data (from gyro) besides course over ground (cog) and speed over ground (sog) data (from gps).

Without heading data, the display will display True & Theoretical wind once the ships speed is above 1kt. The display will assume the heading is identical to the course for True and Theoretical calculations. Keep in mind this can lead to deviations in situations where you experience significant drift or if the vessel is reversing!

5.2.2 Speed through water (VHW from speed log) vs Speed over ground (gps)

Speed through water can be used instead of speed over ground.

The display will not compensate for drift, but will give the theoretical & true wind data as if the vessel would be still in the water (not necessarily according to ground).

6 Wind Orientation Reference Requirements

Required NMEA data for specific Reference:

Relative:	MWV Relative
Theoretical:	MWV Theoretical
	MWV relative + Speed (VTG/GGA* or VHW)
True:	MWD
	MWV Relative + Speed (VTG/GGA* or VHW) + Heading (THS or HDT)**
	MWV Relative + Speed (VHW) AND Heading (THS or HDT)

* VTG will be ignored if the SOG < 1kt to avoid incorrect COG data.

** Optional: Heading data is required to compensate for drift. Without heading data, drift will result in a deviation.

7 Terms, Abbreviations & Symbols list

7.1 Terms & Abbreviations used in this manual.

Advanced	Advanced menu protected by password
Average	Interval over which the average wind speed & direction is calculated
COG	Course Over Ground
Course	Actual direction the vessel is moving (over ground).
Dimming Control	Selected means of regulation of the backlight
Heading	Direction the bow of the vessel is pointing.
Options	Option slot information
QFE	Barometric Pressure at Runway Level
QNH	Barometric Pressure at Sea level
Relative	Wind direction & speed as measured.
Sensor 1	Sensor connected to port 1 of the display
Sensor 2	Sensor connected to port 2 of the display
SOG	Speed Over Ground
True	True wind direction & speed related to North
Theoretical	Wind direction & speed as if the vessel would have no speed; True wind speed & direction related to the bow of the vessel.
Wind Variation	The variation in wind direction over the selected Average interval.

7.2 Symbols



Select between Day or Night mode.
In Night mode a darker color palette reduces the emitted light intensity.



Brightness slider bar.
In Automatic or NMEA control mode use this to set an offset.



Settings menu

8 Digital interface

8.1 NMEA software

8.1.1 Inputs:

The Display accepts the following NMEA input messages with a maximum rate of 4 per second:

\$xxDDC	Dimming control of backlight
\$xxGGA	GPS Lon Lat position
\$xxGMP	GNSS Map Projection Fix Data
\$xxGST	GNSS Pseudo range Error Statistics
\$xxHDT	Heading from Gyro (replaced by \$xxTHS, display accepts both)
\$xxMWD	True Wind
\$xxMWV	Relative or Theoretical Wind
\$xxTHS	Heading from Gyro
\$xxVER	Version info
\$xxVHW	Speed through water (direction is not used)
\$xxVTG	Speed and direction over ground
\$xxXDR	Air Temperature, Sea Temperature, Humidity, Dew point, Barometric Pressure (measured), Barometric Pressure QNH (Sea level), Barometric Pressure QFE (Runway level)

8.1.2 Outputs:

All recognized input messages can be copied to the output

Calculated messages

\$xxMWV	Relative or Theoretical Wind
\$xxMWD	True Wind

Other functions

\$xxDDC	Dimming control of backlight
\$xxVER	Version info

8.2 NMEA Message description

\$--DDC,a,xx,a,a*hh<CR><LF>
 1 2 3 4

1. Sentence Status Flag
2. Color palette
3. Brightness percentage 00 to 99
4. Display dimming preset 1

\$--GGA,hhmmss.ss,llll.ll,a,yyyy.yy,a,x,xx,x.x,x.x,M,x.x,M,x.x,xxxx*hh<CR><LF>
 1 2 3 4 5 6 7 8 9 10

1. UTC of position
2. Latitude - N/S
3. Longitude - E/W
4. GPS Quality indicator₁
5. Number of satellites in use, 00-12, may be different from the number in view
6. Horizontal dilution of precision
7. Altitude re: mean-sea-level (geoid), meters
8. Geoidal separation, meters
9. Age of Differential GPS data
10. Differential reference station ID, 0000-1023

\$--GMP,hhmmss.ss,c--c,c--c,x.x,x.x,c--c,xx,x.x,x.x,x.x,x.x,x.x,a*hh<CR><LF>
 1 2 3 4 5 6 7 8 9 10 11 12 13

1. UTC of position
2. Map projection identification
3. Map zone
4. X (Northern) component of grid (or local) coordinates
5. Y (Eastern) component of grid (or local) coordinates
6. Mode indicator
7. Total number of satellites in use, 00-99
8. HDOP
9. Antenna altitude, meters, re: mean-sea-level (geoid)
10. Geoidal separation, meters
11. Age of differential data
12. Differential reference station ID
13. Navigational Status Indicator

\$--GST,hhmmss.ss,x.x,x.x,x.x,x.x,x.x,x.x,x.x*hh<CR><LF>
 1 2 3 4 5 6 7 8

1. UTC time of the GGA or GNS fix associated with this sentence.
2. RMS value of the standard deviation of the range inputs to the navigation process. Range inputs include pseudoranges & DGNSS corrections.
3. Standard deviation of semi-major axis of error ellipse (meters)
4. Standard deviation of semi-minor axis of error ellipse (meters)
5. Orientation of semi-major axis of error ellipse (degrees from true north)
6. Standard deviation of latitude error (meters)
7. Standard deviation of longitude error (meters)
8. Standard deviation of altitude error (meters)

\$--HDT,x,x,T*hh<CR><LF>
 1 2

1. Heading
2. degrees True (fixed)

\$--MWD,x,x,T,x,x,M,x,x,N,x,x,M*hh<CR><LF>
 1 2 3 4

1. Wind direction, 0 to 359 degrees True
2. Wind direction, 0 to 359 degrees Magnetic
3. Wind speed, knots
4. Wind speed, meters/second

\$--MWV,x,x,a,x,x,a,A*hh<CR><LF>
 1 2 3 4 5

1. Wind angle, 0 to 359 degrees
2. Reference:
 R = Relative
 T = Theoretical
3. Wind speed
4. Wind speed units: K/M/N/S
5. Status, A = Data Valid, V = Data invalid

\$--THS,x,x,a*hh<CR><LF>
 1 2

1. Heading, degrees True
2. Mode indicator:
 A = Autonomous
 E = Estimated (dead reckoning)
 M = Manual input
 S = Simulator
 V = Data not valid (including standby)
 This field shall not be null.

\$--VER,x,x,aa,c--c,c--c,c--c,c--c,c--c,c--c,x*hh<CR><LF>
 1 2 3 4 5 6 7 8 9 10

1. Total number of sentences needed, 1 to 9
2. Sentence number, 1 to 9
3. Device type
4. Vendor ID
5. Unique Identifier
6. Manufacturer serial number
7. Model code (product code)
8. Software revision
9. Hardware revision
10. Sequential message identifier

\$--VHW,x.x,T,x.x,M,x.x,N,x.x,K*hh<CR><LF>
 1 2 3 4

1. Heading, degrees True
2. Heading, degrees Magnetic
3. Speed, knots
4. Speed, km/hr

\$--VTG,x.x,T,x.x,M,x.x,N,x.x,K,a*hh<CR><LF>
 1 2 3 4 5

1. Course over ground, degrees True
2. Course over ground, degrees Magnetic
3. Speed over ground, knots
4. Speed over ground, km/hr
5. Mode Indicator:
 - A = Autonomous mode
 - D = Differential mode Corrections from ground stations or Satellite Based Augmentation System (SBAS).
 - E = Estimated (dead reckoning) mode
 - M = Manual input mode
 - N = Data not valid
 - P = Precise. Satellite system used in precision mode. Precision mode is defined as no deliberate degradation (such as selective availability) and higher resolution code (P-code) is used to compute position fix. P is also used for satellite system used in multi-frequency, or Precise Point Positioning (PPP) mode
 - S = Simulator mode

This Mode Indicator field shall not be a null field.

\$--XDR,a,x,x,a,c--c,.....a,x,x,a,c--c*hh<CR><LF>
 1 2 3 4 5 6

1. Transducer type, Transducer #1
2. Measurement data, Transducer #1
3. Units of measure, Transducer #1
4. Transducer #1 ID
5. Data for variable # of transducers

6. Transducer 'n'1

Recognized XDR messages:

Parameter	1	2	3	4	remarks
Temperature (Celsius)	C	xx.x	C		4 <> WATER or DP
Humidity (Relative in %)	H	xx	P		4 = ignored
Dewpoint (Celsius)	C	xx.x	C	DP	
Barometric pressure (Bar)	P	xx.x	B		4 <> QNH or QFE
Barometric pressure QNH (Bar)	P	xx.x	B	QNH	
Barometric pressure QFE (Bar)	P	xx.x	B	QFE	
Water temperature (Celsius)	C	xx.x	C	WATER	

9 Connections

9.1 Main connections

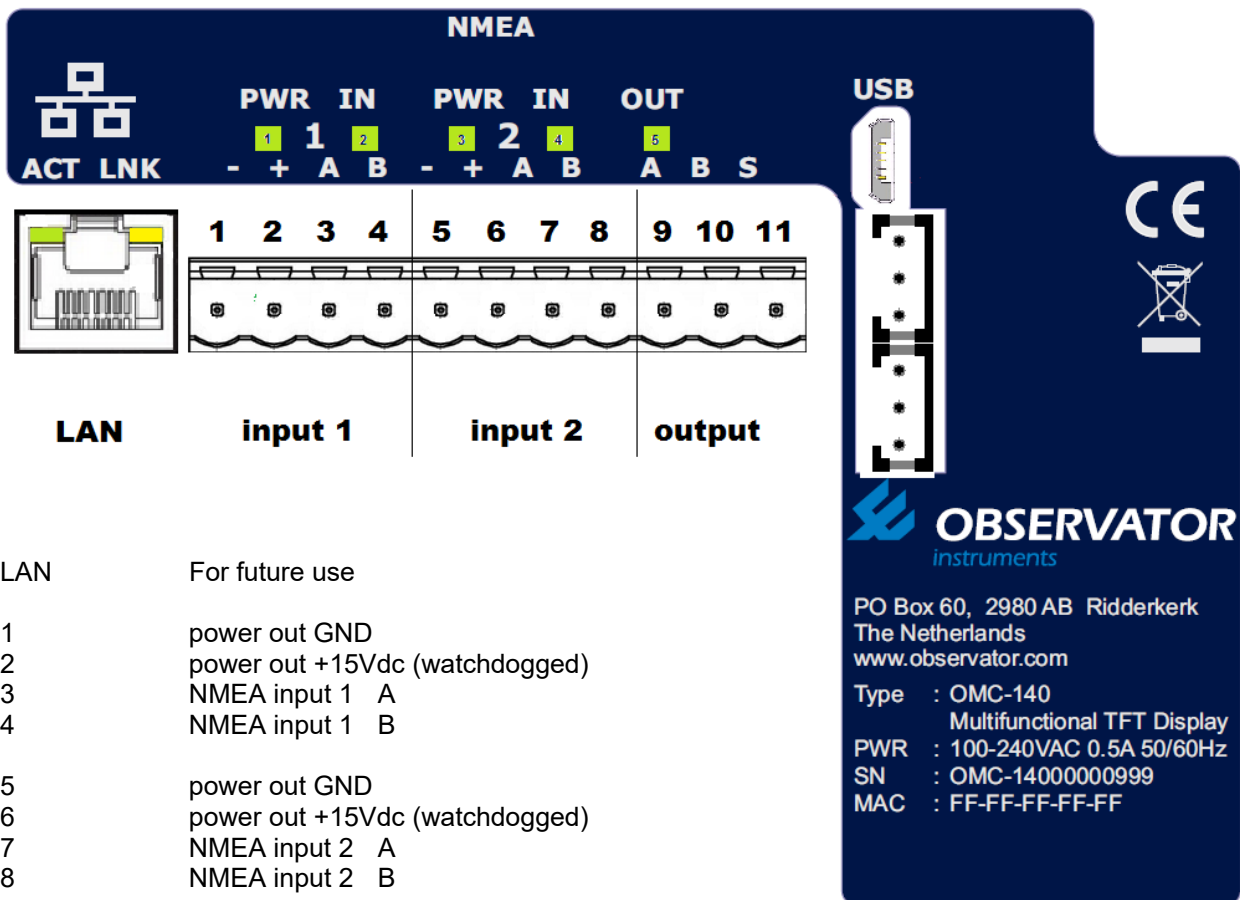

LAN For future use

1 power out GND
2 power out +15Vdc (watchdogged)
3 NMEA input 1 A
4 NMEA input 1 B

5 power out GND
6 power out +15Vdc (watchdogged)
7 NMEA input 2 A
8 NMEA input 2 B

9 NMEA output A
10 NMEA output B

11 Shield connection

USB Micro USB connection for advanced programming and firmware updates.

Display Bus Interconnection bus between displays

LED Function

1 Power input 1
2 Data input 1
3 Power input 2
4 Data input 2
5 Data output

9.2 DC power module connections

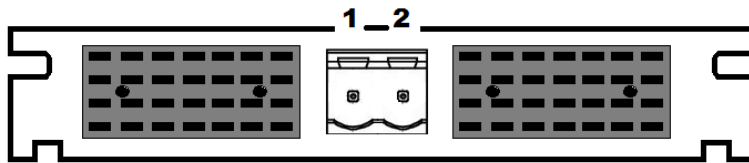

DC power

- | | |
|---|------------------|
| 1 | GND |
| 2 | Power +9 – 30VDC |

9.3 Remote keypad and relay module

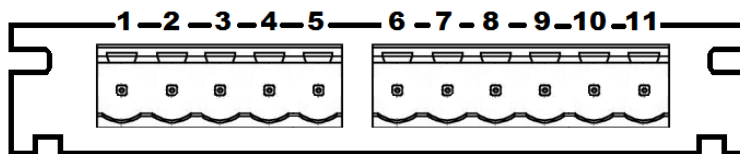

Remote Keypad
 1.. 5 not specified.

Relay outputs

- | | |
|----|--------------------|
| 6 | Relay 1 NO contact |
| 7 | Relay 1 Common |
| 8 | Relay 1 NC contact |
| | |
| 9 | Relay 2 NO contact |
| 10 | Relay 2 Common |
| 11 | Relay 2 NC contact |

10 Options

10.1 Remote control unit

The optional remote controller has 4 buttons to control some functions remotely on the **Main** screen.

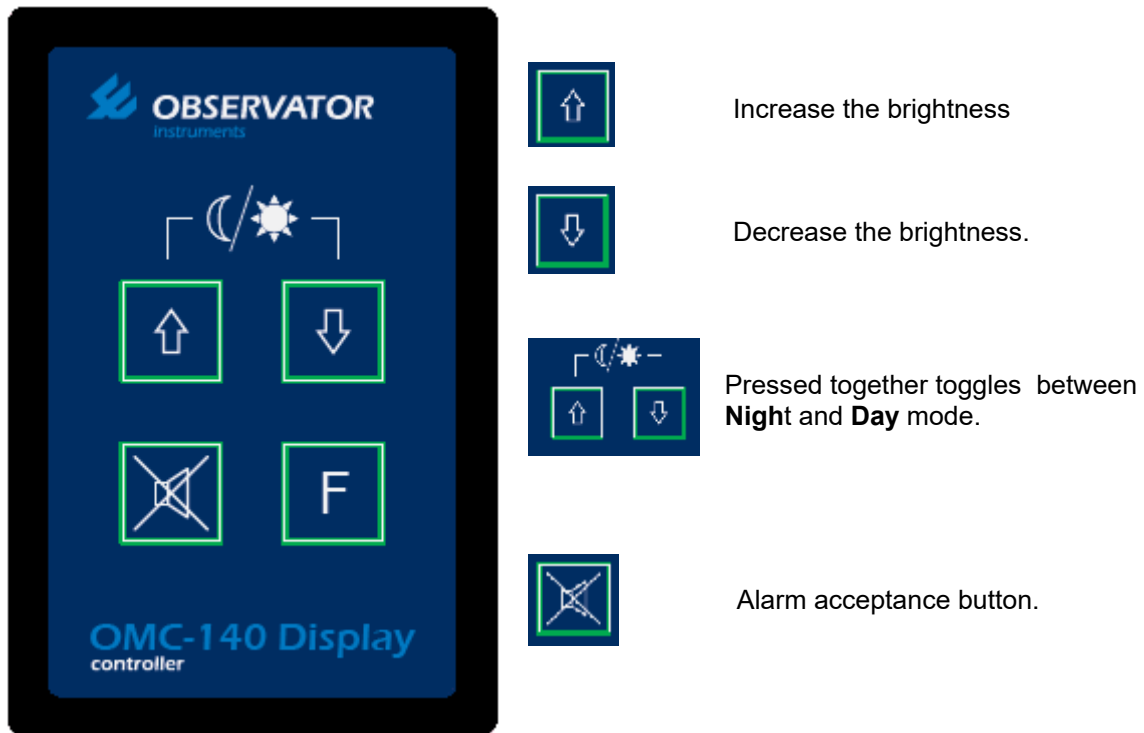

Default the remote is in **Brightness control mode**. If no button press has been detected for 10 seconds it will return to this mode.

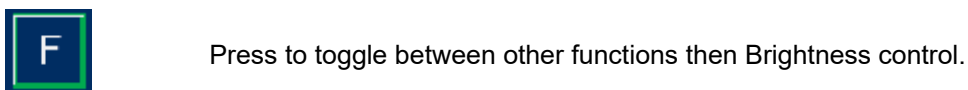

The background of a function will change to bright blue. For example the Average interval.

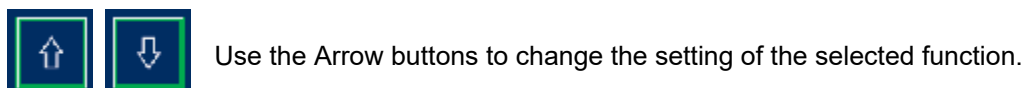

11 Specifications

11.1 Inputs/Outputs

- 2 NMEA0183 inputs
- 1 NMEA0183 output
- Micro USB (programming purposes)
- RJ45 LAN connector (Future use)
- Display interconnection bus

More I/O possible through the option boards

11.2 TFT touch screen

- 8,5" Super Wide Viewing Angle 170° LCD with long life and low power LED backlight
- Active display area: 184.8 x 110.9 mm
- Resolution: WVGA 800x480

11.3 Electrical

- 100..240 Vac, 50/60 Hz, max 50 VA
- 9-30V VDC via Optional DC Power Module
- Sensor 1 and 2 power output 15..16.5 Vdc max 1.5 W
- Connections, pluggable screw terminals for max 2.5 mm²

11.4 Environmental specifications

- Operating temperature –15°C..+55°C
- Storage temperature –30°C..+80°C
- Humidity: 10..93 %RH
- Vibration: IEC 60068-2-6 test Fc
- EMC: IEC 60945; IEC 61326-1
- IP rating: IP22 when fully flush mounted (228 x 142mm)

11.5 Dimming possibilities

- From 0,5..700 cd/m²
- Day and night pallet selectable
- Manual by means of 'slider bar'
- Automatic by means of ambient light sensor
- Central by means of NMEA DDC input

11.6 Dimensions (see drawings on following page)

- Packing 30 x 30 x 40 cm
- Weight 1.2 kgs (excl packing)
- Weight 3 kgs (incl packing & mounting materials)

11.7 Alarms

- Build-in alarms on parameters and system functioning
- Outputs, potential free relay outputs through optional OMC-140-2 module

11.8 In accordance with

- DNV Standard for Certification No. 2.4
- EMC Directive 2014/30/EU
- LV Directive 2014/35/EU
- RoHS Directive 2011/65/EU
- EMC: ESD IEC 61000-4-2; Radiated Immunity IEC 61000-4-3; Conducted Immunity IEC 61000-4-6; Fast Transients IEC 61000-4-4; Surge IEC 61000-4-5
- Electrical safety: IEC 61010:2010
- NMEA 0183 version 4.10 / IEC 61162-1:2010
- IEC 62288:2008 Draft IEC 62288:2012
- All relevant IMO resolutions
- WMO / ICAO / CAP

12 Dimensional drawings

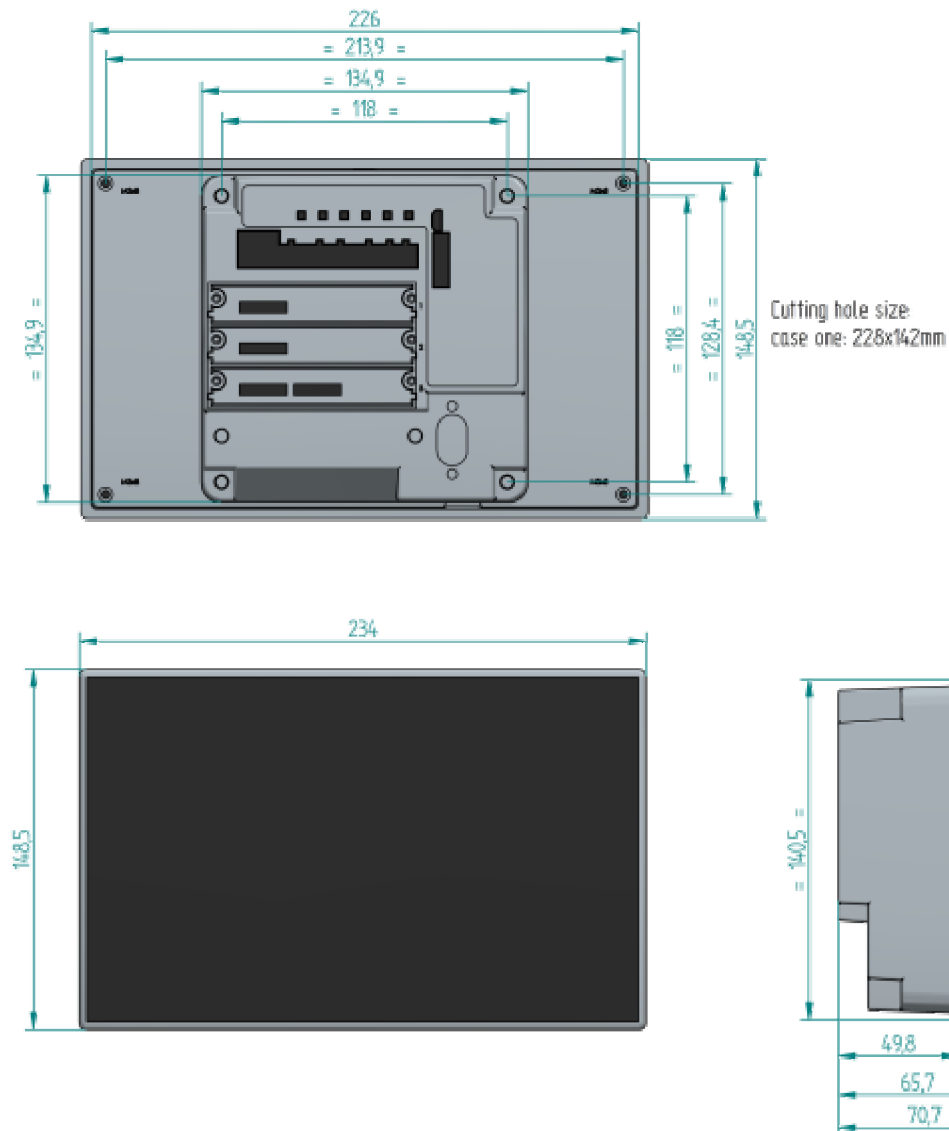

13 Menu structure Touch screen



Opens settings menu

General

Dimming Control:

Manual
Automatic
NMEA DDC

Sensor selection:

Auto
Sensor 1
Sensor 2

Average *(Wind only)*

10 minute
2 minute
Instant
User (settings from User Average Interval)

Wind Speed *(Wind only)*

Bft
Mph
m/s
kn
km/h

Wind Reference *(Wind only)*

Relative
Theoretical
True

User Average Interval *(Wind only)*

Wind Speed
Wind Direction
Gust
Wind Variation

Advanced

Keypad

085	Shows Operator available codes'
0851	Terminal input 1
0852	Terminal input 2

Offset Sensor 1 *(Wind only)*

Offset Sensor 2 *(Wind only)*

Display Mode

Landscape
Portrait

Marked Discontinuity (On / Off) *(Wind only)*

Wind Alarm (On / Off) *(Wind only)*

Wind Alarm (settings) *(Wind only)*

Wind Alarm
Pre Alarm
Hysteresis
Alarm Delay

Output Baudrate

4800
9600
19200
38400

Secure User Items

Average	(un)lock	<i>(Wind only)</i>
Wind Speed	(un)lock	<i>(Wind only)</i>
Dimming Control	(un)lock	
Sensor Selection	(un)lock	
Wind Reference	(un)lock	<i>(Wind only)</i>

System Name (GPS only)

Edit GPS names (GPS only)

Options

Displays installed option boards

Info

Displays System & Product info.

Front *(only visible in Advanced Menu)*

Edit data fields in Front screen

Sensors (*only visible in Advanced Menu*)

NMEA VER Message Table

14 Appendix: Declaration of Conformity



Observator Instruments B.V.

Rietdekkerstraat 6
2984 BM Ridderkerk
The Netherlands

P.O. Box 60
2980 AB Ridderkerk
The Netherlands

Tel.: +31 (0)180 463411
Fax: +31 (0)180 463530

Email: info@observator.com
Internet: www.observator.com
CoC: 24172722

EU DECLARATION OF CONFORMITY

- (1) Apparatus model : **OMC-140**
 - (2) Manufacturer :
Observator instruments B.V.
Rietdekkerstraat 6
2984 BM Ridderkerk
The Netherlands
 - (3) This declaration of conformity is issued under the sole responsibility of the manufacturer.
 - (4) Object of the declaration :

OMC-140 Multifunctional TFT Display
OMC-140-01 DC power supply option module
OMC-140-02 Remote control & relay output module
 - (5) The object of the declaration described above is in conformity with the relevant Union harmonisation legislation:
 - Directive 2014/30/EU of the European Parliament and of the Council of 26 February 2014 on the harmonisation of the laws of the Member States relating to electromagnetic compatibility
 - Directive 2014/35/EU of the European Parliament and of the Council of 26 February 2014 the harmonisation of the laws of the Member States relating to the making available on the market of electrical equipment designed for use within certain voltage limits
 - Directive 2011/65/EU of the European Parliament and of the Council of 8 June 2011 on the restriction of the use of certain hazardous substances in electrical and electronic equipment
 - (6) References to the relevant harmonised standards used:

EN IEC 60945:2002 including EN IEC 60945/C1:2008
EN IEC 61326-1:2013
EN IEC 61010-1:2010 including EN IEC 61010-1/C1:2011 and /C2:2013
EN 50581:2012
 - (7)
 - (8) Ridderkerk, 11 March 2015,
Observator instruments
- Dr. Ir. R. de Vries
CEO
- 