

PRODUCT BROCHURE

# Wet Gas Extractive Dust Measurement EXO

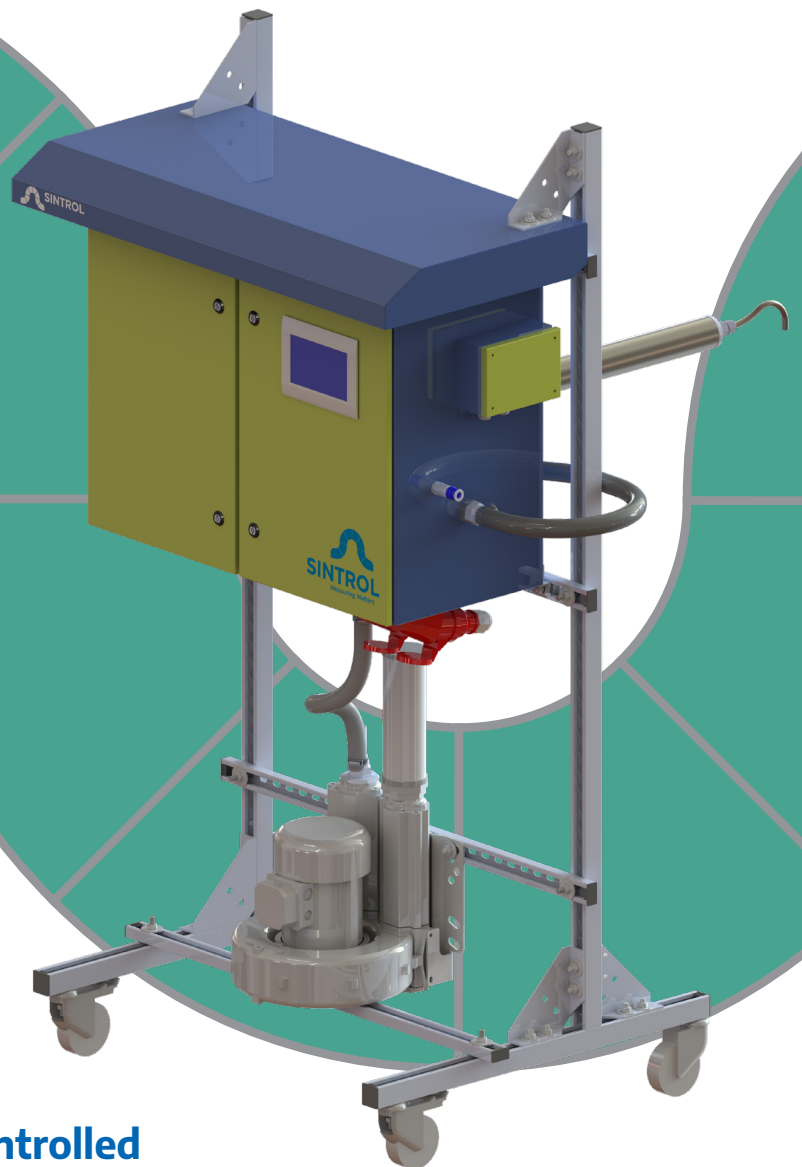

CE

 **RoHS<sub>2</sub>**  
2011/65/EU

Temperature controlled  
continuous particulate  
measurement for  
wet processes

  
**SINTROL**  
Measuring Matters

# LED based, forward scattering instrument to measure dust concentrations in difficult wet gases.

- Isokinetic sampling in variable flow conditions
- Continuous dust levels as low as 0,1 mg/m<sup>3</sup>
- Sample stream isolated with air curtain to keep the optics clean -> long maintenance interval
- Accurate linear measurement for all kinds of dust
- Color touch screen for easy parametrization
- LED light source covers different particle size distributions and is less affected by particulate characteristic

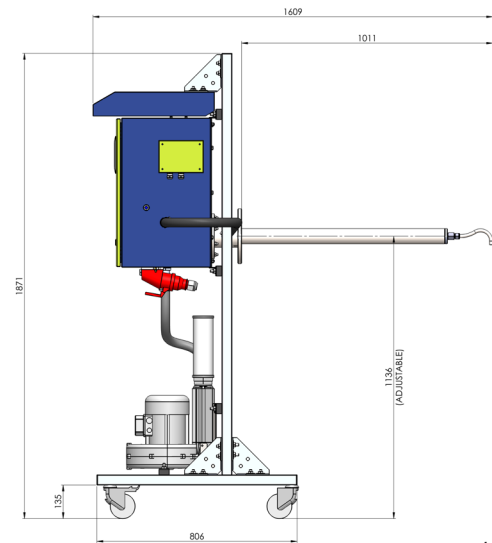

SINEXO/04032022

Product Name	EXO Optical Wet Gas Extractive Dust Monitor
Measurement	Total Dust, Optical LED Based, Extractive
Particle Size	From 0,01 µm
Detection limit	From 0.1 mg/m <sup>3</sup>
Measurement range	0-500 mg/m <sup>3</sup> (user changeable)
Power supply	400V/16A 3-Phase
Power consumption	Total: max 3.7 kW , heaters max 1,5 kW, blower max 2,2 kW
Purge air supply	Clean, dry instrument air ~30 l/min or separate purge air blower
Output Signals	<ul style="list-style-type: none"> <li>• 2x8 digital output, 24 VDC , 0,5 A</li> <li>• Two 4-20 mA output</li> <li>• Ethernet TCP/IP</li> <li>• USB for datalogging</li> </ul>
Signal Averaging Time	1 sec , 30 sec or user selectable (max 3600 sec)
Ambient Temperature	-20...+50°C
Stack process conditions	Flue gas below dew point with water droplets
Ambient humidity	Max 95 % RH (non-condensing)
Flue Gas Velocity	5-25 m/s
Calibration	SRM (standard reference method), gravimetric sampling
Enclosure	Powder coated steel, IP54
Size	W: 800 mm, H: 400 mm, D: 300 mm
Weight	Total weight fully assembled ~120 kg, depending auxiliaries